

U510

Installation Instruction Sheet

| | |
|-------------|---------------------------------------|
| NTD-001 | Turn knob with set screw |
| NTD-002 | HL100 coin box lock & key |
| NTD-003 | Coin & denomination label |
| NTD-510-001 | Tampon weight |
| NTD-510-002 | Napkin weight |
| NTD-004 | Coin box |
| NTD-005 | Napkin rotor cam |
| NTD-006 | Tampon cam drive rod |
| NTD-007 | Chassis plate assembly |
| NTD-010 | Coin mechanism (.10, .25, .50 & Free) |

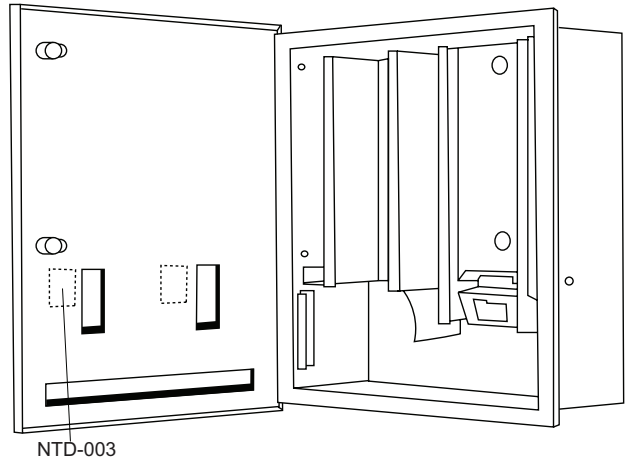

Overall Size: 17 1/2"W x 27 1/2"H x 4 3/4"D
Wall Opening: 15 3/4"W x 25 3/4"H x 4"D
Capacity: Napkins 15, Tampons 23
Storage: Napkins 10, Tampons 40

Package Sizes Dispensed:

Napkins:

Min: 2 5/8"W x 4 1/8"L x 3/4"H
 Max: 3 1/8"W x 4 1/2"L x 1 1/8"H

Tampons:

Min: 5/8" Dia. x 4 1/4"L
 Max: 3/4" Dia. 5 1/8"L

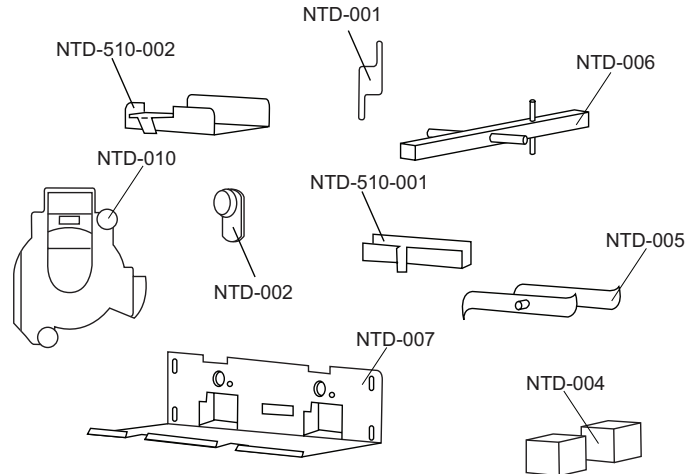

INSTALLATION & TROUBLESHOOTING

Recessed Units: Secure recessed units to framing of rough wall opening with four (4) #10 screws provided.

Surface Units: Secure surface mounted units to wall surface through back of unit with four (4) #10 screws provided.

Recommended Mounting Height: Finished floor to turn knob mechanism 40" for ADA compliance.

Troubleshooting

My Unit Will Not Accept Coins: Check to see if chutes are empty. This unit has an automatic empty indicator which prevents coins from entering slot when chute is empty.

The Packages Get Hung Up In Chute: Check packages for size as recommended by manufacturer. Make sure packages have not been wet, bent, crushed or are out of shape in any other manner.

Check if weight is being used properly over packages to be dispensed in each chute. Check chutes and front door to see if it has been vandalized or tampered with. In many cases chutes are damaged when units are vandalized. If chutes cannot be straightened, they should be replaced.

FEATURES & INSTRUCTIONS

1. Peel off coinage labels
2. Separate coin box lock from door locks
3. Two separate mechanisms that can operate independently of one another and at different coinages. If one is damaged or breaks, it can be individually replaced.
4. Weights will indicate on turn knob mechanisms when chutes are empty and will not allow coins to be inserted.
5. High storage capacity

Refilling The Vendor

Napkins: Remove weight from napkin chute and fill with napkin packages. Replace weight on top of napkins and store reserve napkins in storage area.

Tampons: Remove weight from tampon chute and fill with tampons. Replace weight on top of tampons and store reserve tampons in storage area.

Ordering Labels: When ordering labels or mechanisms specify product and coinage for proper labels.